

DISHWASHER VALVES

SPECIFICATIONS

S-54 Model specifications for the following parts:

DW-154
 DW-155
 DW-156
 DW-157
 DW-158
 DW-159
 DW-160
 DW-163
 DW-163B
 DW-164
 DW-165
 DW-166

This series features a body of stabilized plastic designed to cope with a variety of adverse water conditions throughout the country. It was designed for use specifically with garden hose inlet connections on portable dishwashers. This valve model also has a reduced air gap operator, or water hammer suppression feature.

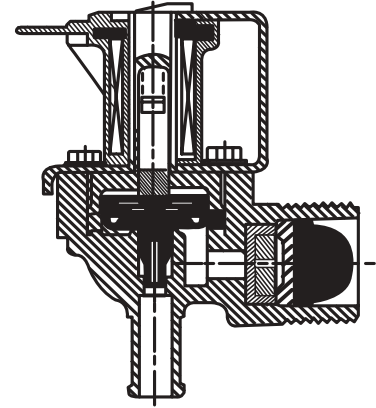
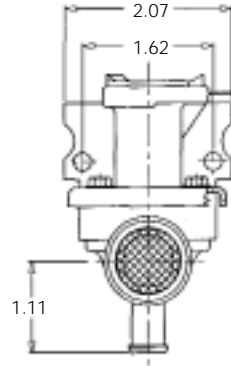
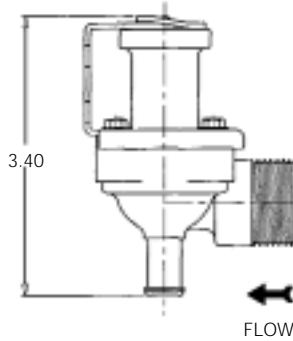
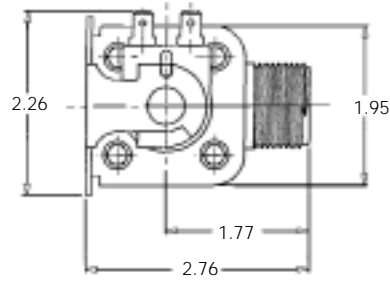

SPECIFICATIONS

N-53 Model specifications for the following parts:

DW-253
 DW-254
 DW-256
 DW-258

This model features a brass inlet fitting and mounting bracket design which allows direct connection to the supply plumbing without applying torque to the valve body. It also has an inlet screen and the flood protection of two valves in series within a single compact body. This valve also has a reduced air gap operator, or water hammer suppression feature.

