

COMMERCIAL REFRIGERATION DEFROST CONTROLS

WIRING DIAGRAMS FOR 8040 SERIES

ELECTRIC HEAT DEFROSTING

MODELS 8045-00 AND 8045-20

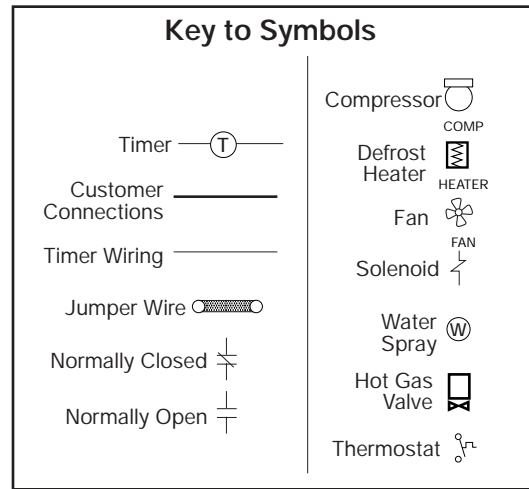
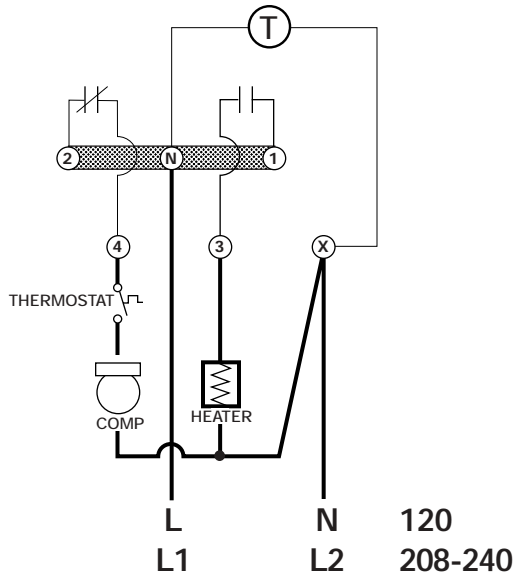

Heater not to exceed 4000 watts at 120VAC or 8000 watts at 240VAC.

ELECTRIC HEAT DEFROSTING

MODELS 8041-00 AND 8041-20

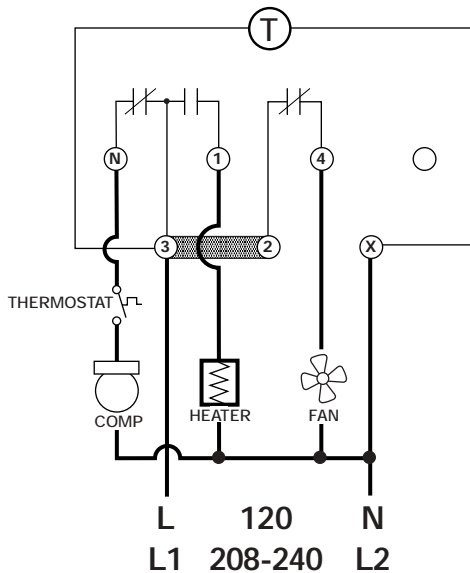

MODELS 8047-00 AND 8047-20

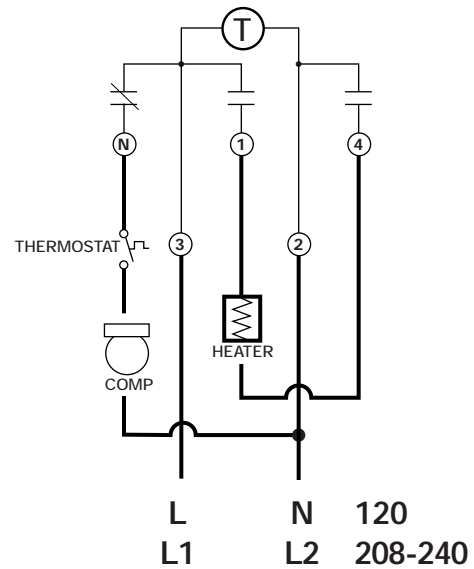

Fan and compressor loads not to exceed 2 hp. Heater not to exceed 4000 watts at 120V AC or 8000 watts at 240V AC.

The method of wiring shown is for an electric heat defrost system breaking both sides of the heater circuit.